

# Hoffman|Controls

## Installation and Operating Instructions

706-FFS (TB) Series

### VariFlow™ Furnace Fan Speed Controller

## General Description

The VariFlow™ Furnace Fan Speed is an electronic variable motor speed Controller that increases system efficiency and improves indoor air comfort by varying the air flow in constant volume central air conditioning systems.

The Controller's purpose is to reduce fuel consumption and operating cost by more effectively utilizing the energy of a cycle and concurrently improve comfort by mixing stratified air to obtain a more uniform space temperature. This function recovers the residual energy left in the system at the end of the cycle and mixes it with the stratified air to increase or decrease the mean effective space temperature. The higher/lower mean effective temperature extends the "off cycle" and/or precludes an early requirement for energy to heat or cool the space.

To accomplish the above, VariFlow™ continues to reduce air flow after residual energy is recovered and delivered to the space to assure that stratification of air does not adversely effect space temperatures.

The Controller may be field programmed at the discretion of the installer/user to "cycle off" once minimum speed is obtained, or "continue at minimum speed" until the next cycle occurs.

VariFlow™ functions before and after the heating/cooling cycle. Flow during the cycle is at constant volume as specified by the original equipment manufacturer.

VariFlow™ functions as an auxiliary control to the original equipment manufacturer's primary control system. Variable air flow occurs before each heating cycle begins and after each heating or cooling cycle ends. Manufacturer's original controls function undisturbed as per original design.

## Pre-Installation

### The 706-FFS (TB) Series Controllers:

1. **Must be installed inside the furnace blower cabinet in the return air plenum.** The wiring connections will vary depending on the specific original control components that are used. Color coded wires (flying leads) are furnished on the 706-FFS to facilitate wiring of the Controller to the appropriate terminal location in the furnace (See Table 1 for basic Control Wiring Methods and Connections).
2. **Must be used only with** direct drive PSC (Permanent Split Capacitor) or Shaded Pole Motors. (Belt drive blowers not applicable.)

## CAUTION



Controller requires permanent connection to line voltage wiring that is electrically "HOT". Do not proceed with wiring until all line voltage has been disconnected from the furnace.

3. Set System Thermostat Switch to "OFF", Fan Switch to "Auto" before installation.
4. Installation should be accomplished by qualified, experienced technicians familiar with warm air heating and AC equipment, electromechanical and/or electronic controls.

## Programming Options

The installer/user may program fan to:

- a. "Cycle off" at end of 10 min "Ramp Down", or
- b. Continue at "Minimum Speed" until next cycle occurs.

The Controller is furnished factory standard with a "Jumper Tab" installed for "cycling fan off" at end of "Ramp Down", as per a. above. Removing "Jumper Tab" will program for "continuous minimum" speed after "Ramp Down" until the next cycle for Heating or Cooling occurs, as per b. above. Select jumper option before installing Controller.

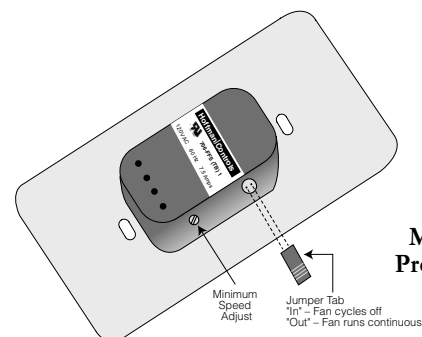

Min. Speed Adjust & Program Tab Locations

Note: Store "Jumper Tab" for future use if not used.

## Mounting Controller

- Provide accessibility for flying lead wiring connections, Min. Speed Adjust and Jumper Tab.
- Mount Controller with two (2) #6 sheet metal screws to control panel or inside of blower cabinet. Do not mount Controller on heat generating surfaces.

# Wiring/Checkout Procedure

1. Technician may elect to monitor voltage to motor (Red and White) with true RMS volt meter, temperature of supply air and elapsed time for performance characteristic of 706-FFS Controller. (See VariFlow™ Variable Volume, Warm Air Heating & DX-Cooling System, Graph 1.)
2. When the Furnace Fan Switch or Timer Delay Relay settings are field adjustable, the following “reset values” are suggested/recommended.

Control	Fan On	Fan Off
Fan Switch	Max. Temp. Allowable	Max. Temp. Allowable
Time Delay	Max. Time Allowable	Max. Time Allowable

**Table 1**  
**706-FFS (TB) Field Wiring/ Connections Description**

Wiring Color Code	Connect to	Connection to Provide	Wiring Diagram Figure
Black	L1 (Hot)	Uninterrupted power source	1 or 2
White	(-) Neutral	Uninterrupted electrical return	1 or 2
Red	Motor (Load)	a) Power to Med. Speed motor tap at Fan Switch (or) Fan Timer b) Power to Med. Speed motor tap at Heat Relay output	1 2
* Orange	Gas Valve	Monitors Gas Valve Operation	1 or 2
* Green	Fan Relay	Monitors High Speed Fan Operation	1 or 2
Yellow	Common	Common of 24V	1 or 2

\* Connect to Hot side of 24V AC (opposite common).

3. **After Wiring Connections are Complete** (see Fig. 1 or 2)
  - a. Replace all panels on furnace to original locations.
  - b. Reconnect line voltage (power) to furnace.
  - c. Set Thermostat to call for heat.
  - d. **Important: Leave Fan Switch in “Auto” position.**
  - e. Set system switch to “Heat”.
4. **Observe Furnace Operation** (see Graph 1)
  - a. After purge and ignition cycle are complete, gas valve will energize and burner ignite.
  - b. Blower will start within 3—10 seconds at Minimum Speed, 400 RPM ±, 35% ± of full flow.
  - c. Blower will slowly increase in speed and flow, on “Ramp Up cycle”, until Full Speed is obtained within approximately one (1) minute.
  - d. Furnace supply air temperature will reach a maximum temperature (steady state) within approxi-

mately 5—6-minutes.

- e. Reset thermostat to a temperature that will cycle burner “OFF”.
- f. Fan will gradually begin to reduce in speed over a 10-minute “Ramp Down cycle”.
- g. At end of 10 minutes, fan will return to minimum speed, 35% ± of Full Flow.
- h. Fan will “stop” or “continue at minimum speed” depending on “Jumper Tab” position.

Installer should reset Thermostat (call for cooling) and observe previously described VariFlow™ operation. **Exception:** Fan will start in High Speed when compressor energizes (see Graph 1).

- i. Return Thermostat to normal temperature settings.

## 5. Special Operating Instructions

- a. To obtain the features and benefits of improved comfort and increased system efficiency:

**Always operate Thermostat Fan Switch in “AUTO” position when heating or cooling is required.**

Operating fan in “ON” position overrides VariFlow™ Furnace Fan Speed function and prevents the function of variable air flow.

- b. Motor design characteristics may effect the noise of the fan motor as speeds approach 400-RPM±. The noise/hum is a function of the motor design, not the Controller’s operation. If motor noise is objectionable:
  - Line blower compartment or return air duct with 1/2” high density duct liner, or
  - Reset minimum speed to higher RPM to eliminate objectionable noise.

## 6. Recalibrating Minimum Speed

706-FFS Series Controllers are furnished with a field adjustable Minimum Speed setpoint. The Minimum Speed has been factory set at mid-range to provide approximately 450± RPM. Minimum Speed varies with each installation based on the motor make, design, loading, static pressure and/or torque characteristics.

Changing the Minimum Speed **is not recommended** unless the installer is able to verify actual final RPM with a Tachometer.

The following procedure is required to recalibrate the Minimum Speed setpoint (see Adj. location, Page 1).

- a. Set Thermostat system switch to “Off”. Set Fan switch to “Auto”.
- b. Remove panels to gain access to 706-FFS (TB) Controller.
- c. Engage “Door Switch” to provide power.
- d. Remove Minimum Speed Jumper Tab from Controller, if Jumper is installed. Disregard this

instruction if Jumper Tab has been removed.

- e. Motor should run at continuous Min. Speed.
- f. Insert 1/8" miniature slotted screwdriver in potentiometer, turn:
  - CW to increase Minimum Speed.
  - CCW to decrease Minimum Speed.
- g. Measure RPM to assure a Minimum Speed of adjust to not less than 450 RPM.
- h. Reinstall Jumper Tab to "cycle off fan" at end of "Ramp Down". Disregard this instruction if "continuous Minimum Speed" is desired.
- i. Replace panels, and reactivate "Door Switch". Observe operation of system as described in Wiring/Checkout Procedure 4 & 5.

## Schematics/Diagrams/Graphs

### Wiring Diagram/Schematic

**Figure 1** — Typical early or mid era control systems utilizing electro-mechanical control components. (May or may not have electronic ignition and or power venter.)

**Figure 2** — Typical late or current electronic warm air furnace control system utilizing Integrated Furnace Control (IFC), electronic ignition and power venter.

### Graphs

**Graph 1, Depiction of FFS** — Motor Speed and variable flow vs. time for heating and cooling. Constant and variable flow rates.

**Graph 2, Depiction of FFS** — Percent of flow, motor energy, blower RPM and voltage over time.

## VariFlow™ Line/Low Voltage Schematic Wiring Diagram

Typical Upflow, Horizontal or Counterflow Central Heating and Cooling System

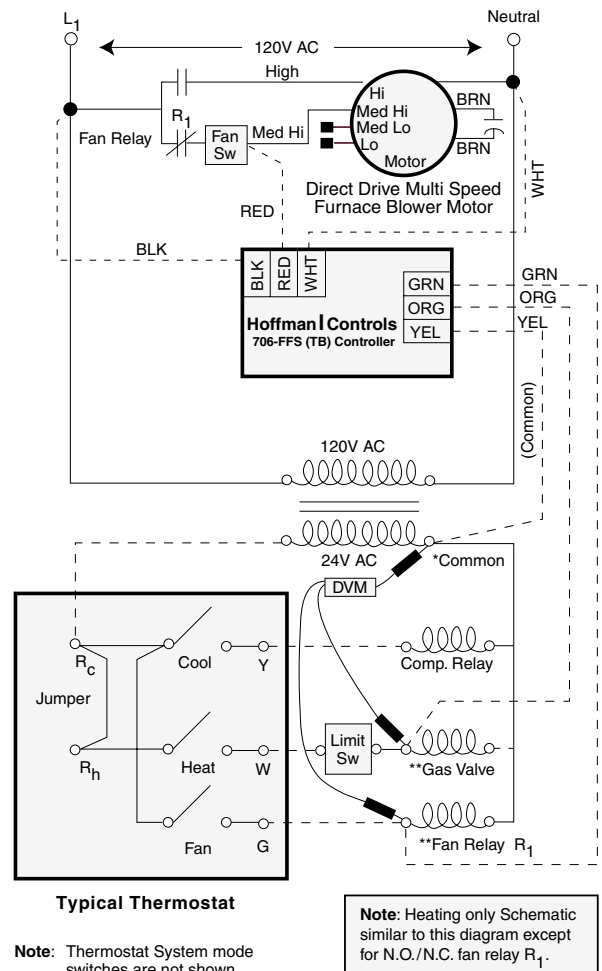
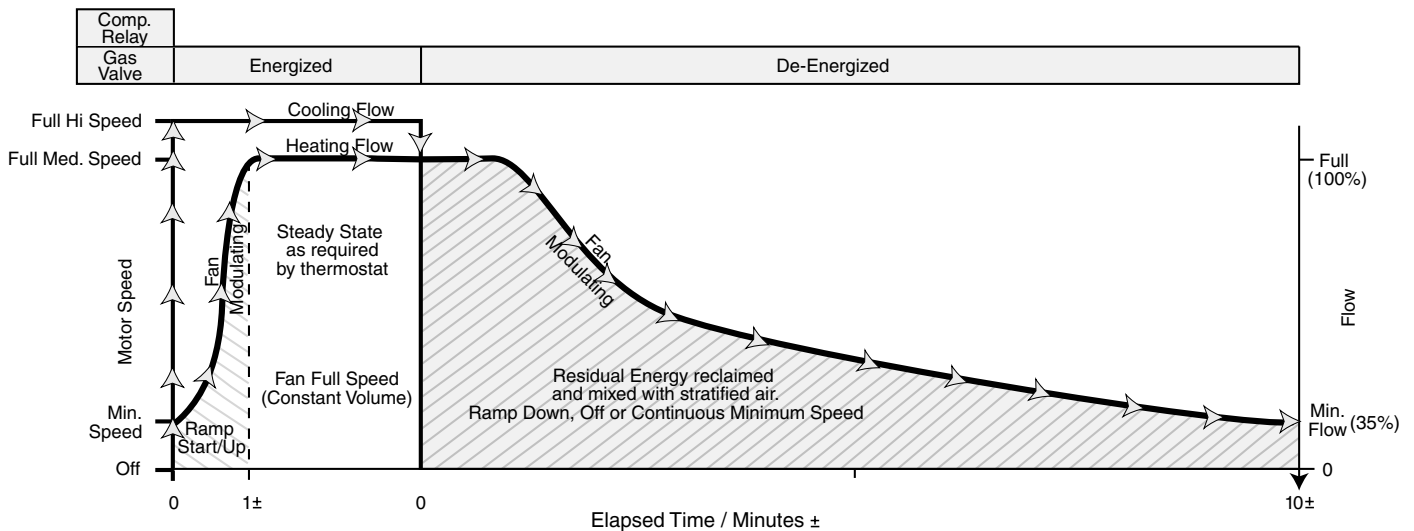
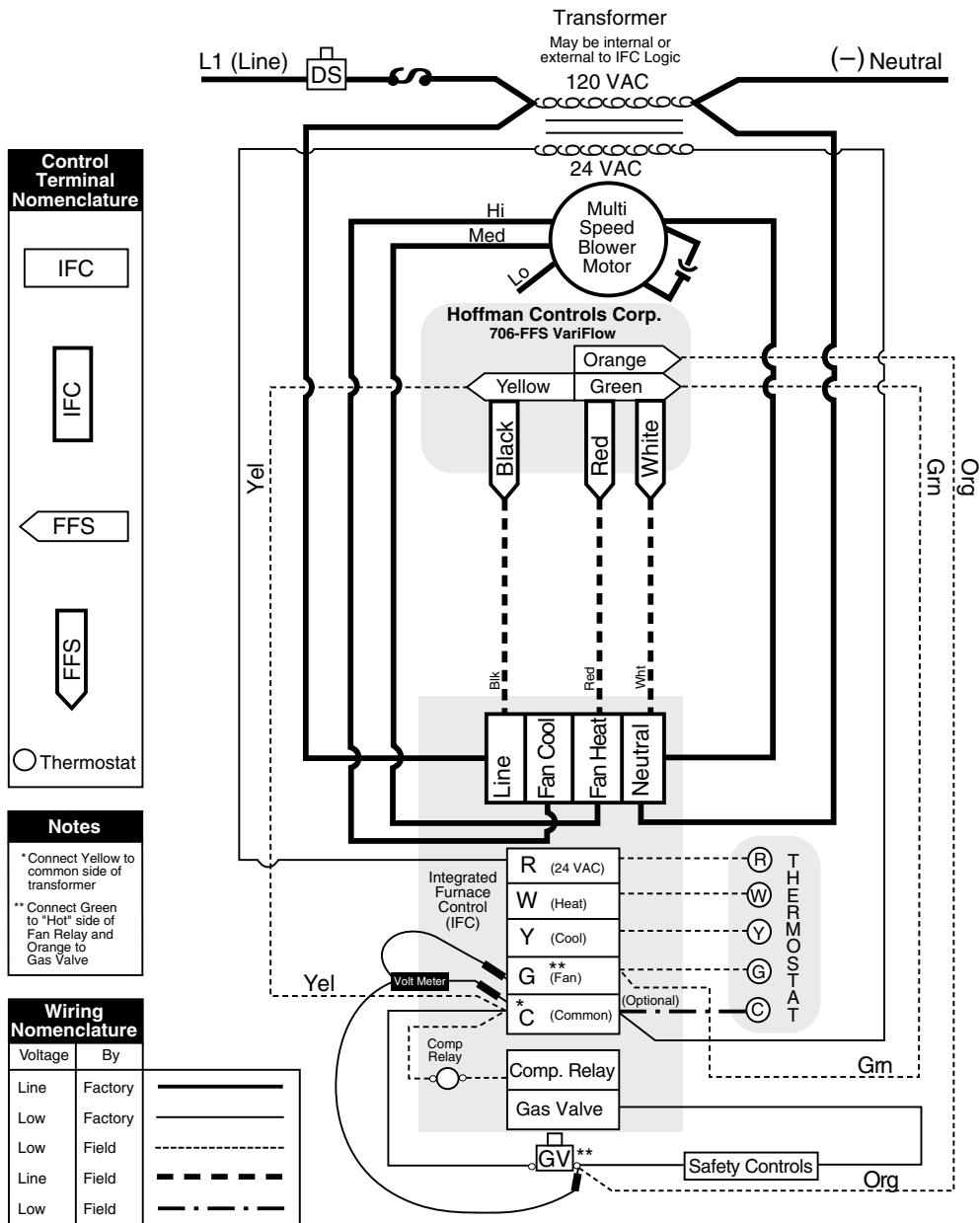
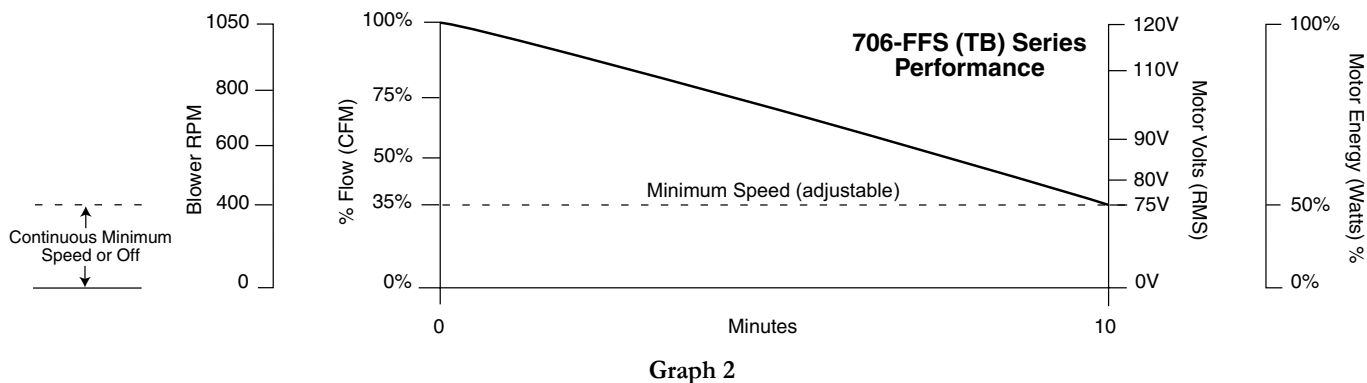

Figure 1





VariFlow™ Integrated Furnace Heating & Cooling Control Wiring Schematic Diagram  
Figure 2



## Hoffman Controls